

SCHEMI ELETTRICI

SM27 - SERIE NT trifase (protettore termico interno + esterno)

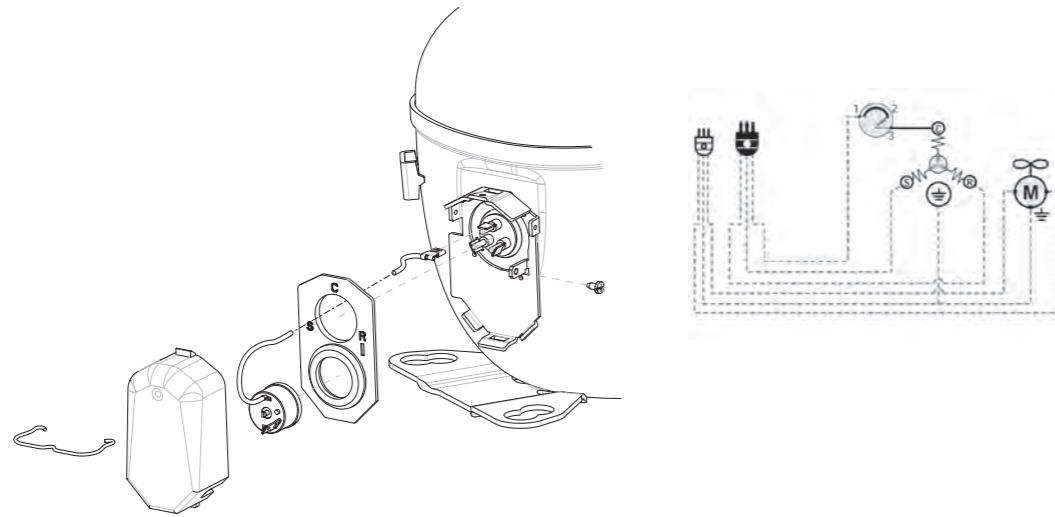

SM29 - CSIR SÉRIES EMX morsettiera, avviatore e 4TM

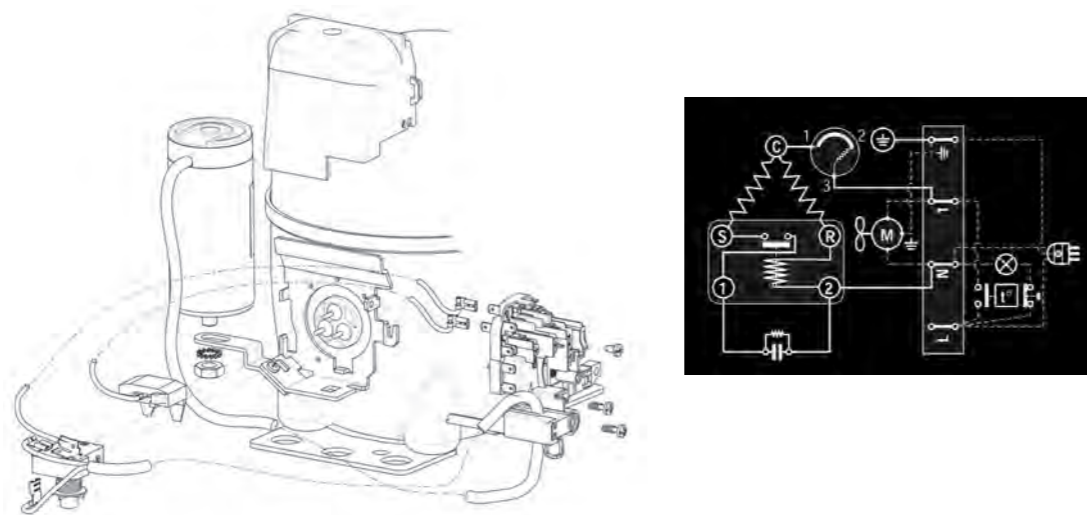

SM32 - RSCR EM PTC & 4TM

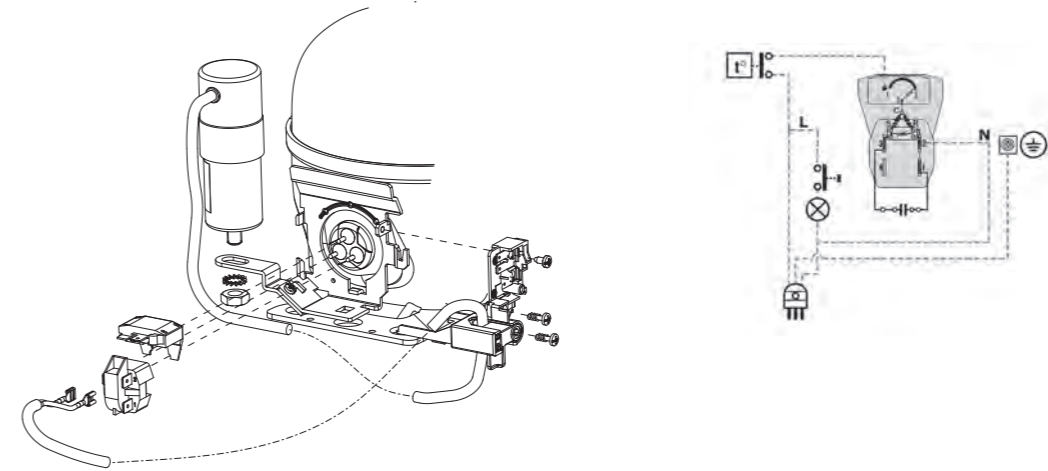

SCHEMI ELETTRICI

CON01 - VEMY6 / VEG (Drop-in)

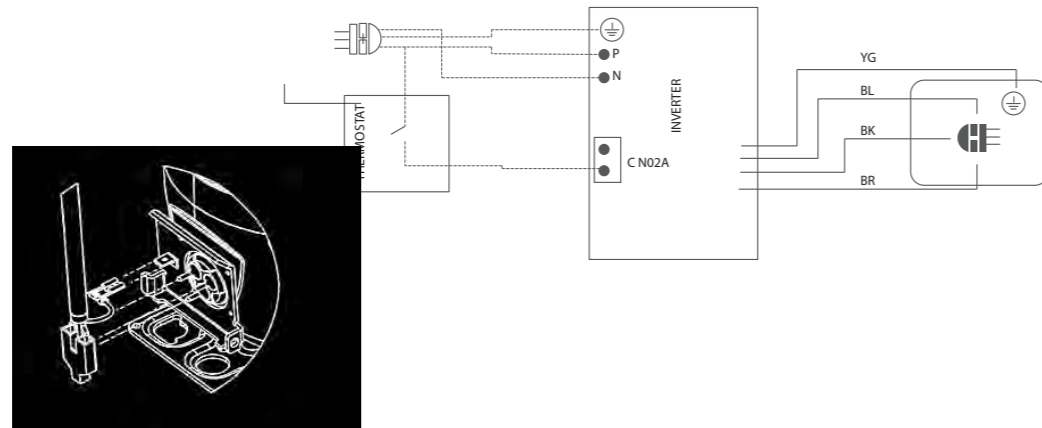

CON02 - VEM / VEG (Frequenza)

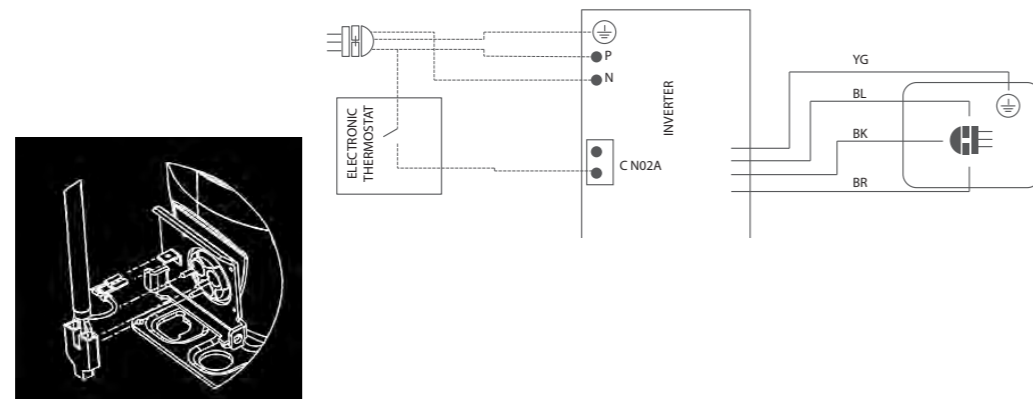

CON03 - VEMY6 / VEG (Seriale)

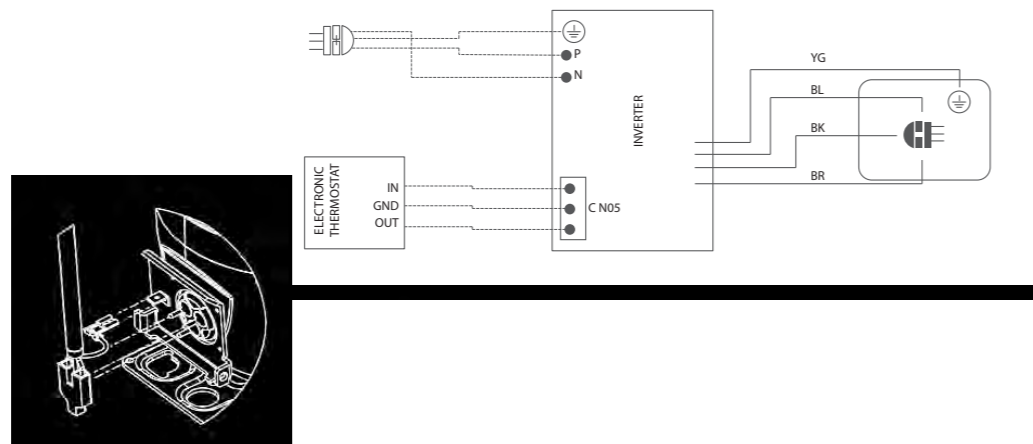

CON04 - VEM (Frequenza)

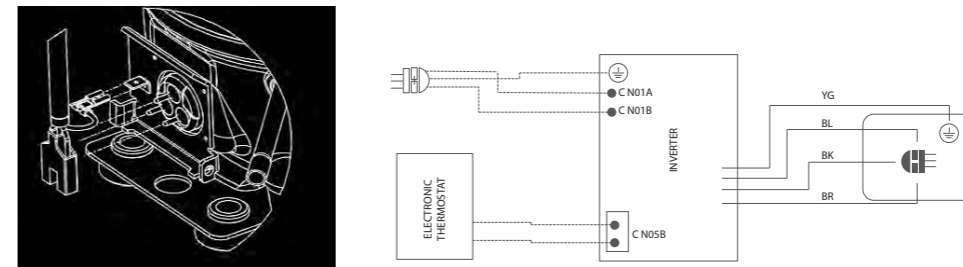

CON05 - VEM (Seriale)

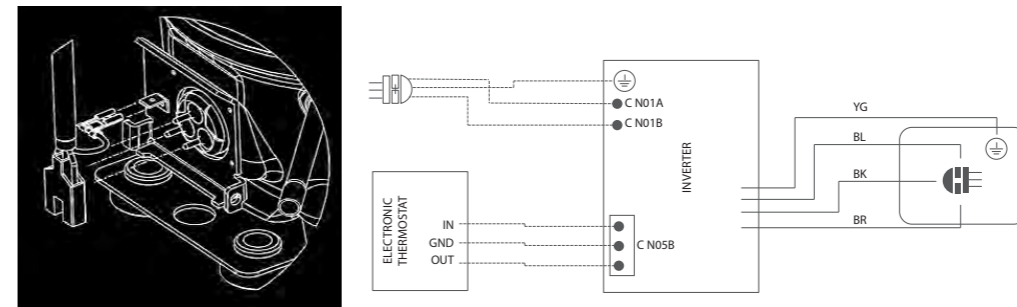

CON06 - VEM (Drop-in)

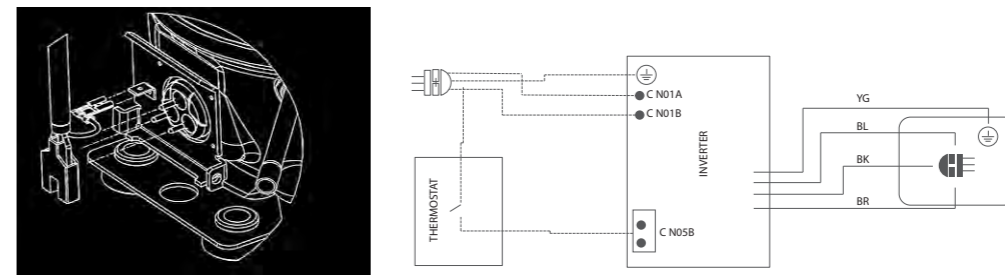

SCHEMI ELETTRICI

CON07 - VNE (Drop-in)

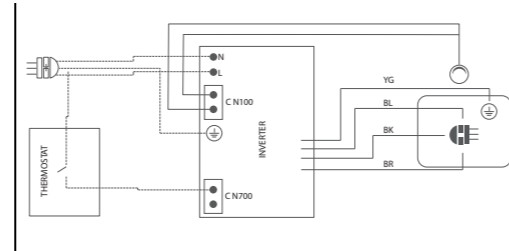
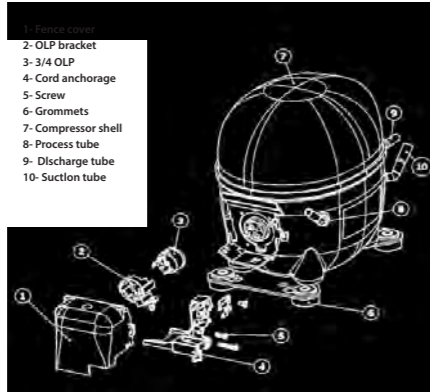

CON08 - VNE (Frequenza)

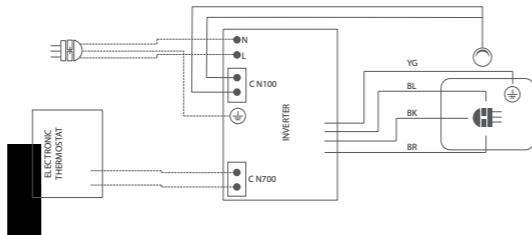
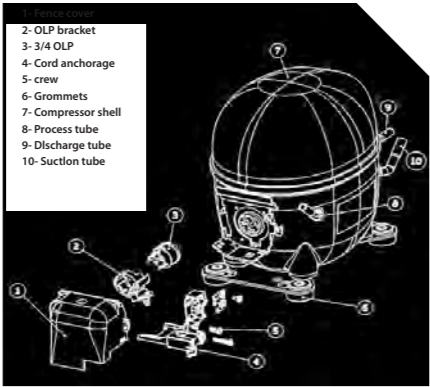

CON09 - VNE (Seriale)

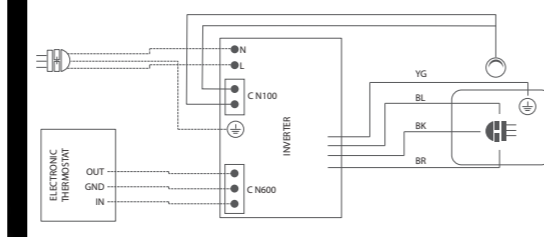
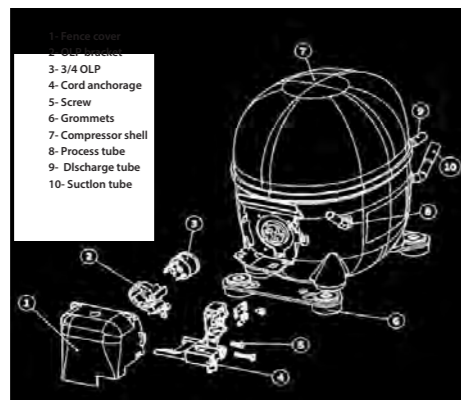

CON10 - VEG (Drop-in)

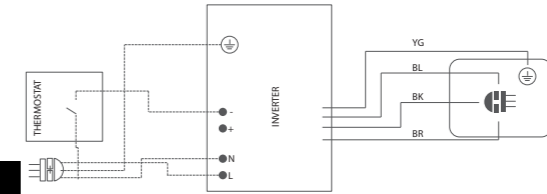
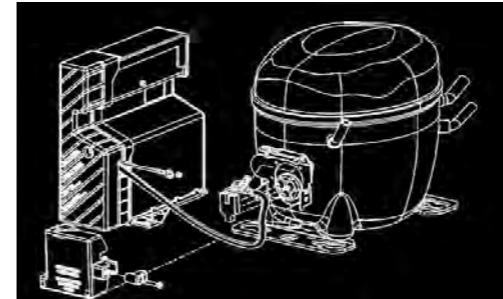

CON11 - VEG (Frequenza)

